

# **REPORT OF THE DPTS/911 TASK FORCE**

**Research Report No. 284**

**Legislative Research Commission  
Frankfort, Kentucky  
July, 1999**

# **REPORT OF THE DPTS/911 TASK FORCE**

**Research Report No. 284**

**Legislative Research Commission  
Frankfort, Kentucky  
July, 1999**

**This report was prepared by the Legislative Research Commission staff and printed with state funds.**

**REPORT OF THE  
DPTS/911 TASK FORCE**

**SPECIAL TASK FORCE ON DPTS/911**

Sen. Dale ShROUT  
Sen. Elizabeth TORI  
Rep. Joe BARROWS  
Rep. John VINCENT  
Ms. Bonnie CUMMINGS  
Mr. Robert CRUTCHER  
Mr. Bill DAVIES  
Mr. J. A. JONES  
Mr. Chuck LAMBERT  
Mr. Ken LEDFORD  
Mr. Todd OETKEN  
Capt. John PATTERSON  
Ms. Mary ROBERTSON  
Capt. John WITT

Rep. James GOOCH, Chairman

Staff: Linda KUBALA, Matt UDIE, and Sheri MAHAN

## **FOREWORD**

The DPTS/911 Task Force was established by 1998 House Bill 560 to examine the issue of requiring owners and operators of private telephone systems to make those systems compatible with enhanced 911 systems. In addition to four members of the General Assembly, the fifteen-member task force includes members representative of business, emergency services, communications providers, industry, and government agencies.

This report, adopted by the task force on May 27, 1999, contains the findings, conclusions, and recommendations of the DPTS/911 Task Force. The report was prepared by Matt Udie, Sheri Mahan, and Linda Kubala. It was edited by Charles Bush.

Bobby Sherman  
Director  
The Capitol  
Frankfort, Kentucky  
July 1, 1999.



## TABLE OF CONTENTS

FOREWORD .....	i
TABLE OF CONTENTS .....	iii
SUMMARY .....	v
I: INTRODUCTION.....	1
II: THE LIMITATIONS OF PRIVATE MULTI-LINE TELEPHONE SYSTEMS .....	5
III: SURVEY OF PSAP EXPERIENCE WITH PRIVATE MULTI-LINE SYSTEMS .....	9
IV: ESTIMATION OF DPTS SYSTEM UPGRADE COSTS.....	15
V: STATE AND FEDERAL ACTION ON DPTS INTERFACE ISSUES.....	21
VI: RECOMMENDATIONS.....	27
APPENDIX A: HOUSE BILL 560.....	29
APPENDIX B: THE 1998 PRIVATE BRANCH EXCHANGE (PBX) SURVEY .....	39
APPENDIX C: STATUTES FROM OTHER STATES REGARDING PRIVATE MULTI-LINE TELEPHONE SYSTEMS .....	43



## **SUMMARY**

### **Background**

People have learned to dial 9-1-1 in an emergency, and expect a rapid, effective response. To improve that response, counties and cities across the country, including about 81 Kentucky counties, have spent additional money and effort to add "Enhanced" or "E911" features to their 911 Emergency Telephone systems. Enhanced systems use the caller's telephone number to route the call to the proper public safety answering point (referred to as PSAP), and to retrieve and display pertinent information for that telephone number when the call is answered.

E911 systems and their related data bases only cover publicly switched telephone numbers, absent special arrangements to incorporate the stations served by private systems. If a caller uses an extension in a Dispersed Private Telephone System (DPTS) to call 911, the call taker will not know his location. Rather, the call taker will have only the location of the switchboard or PBX, which is the interface between the public and private systems. If the private system serves several locations, like different branch banks or schools or apartment units, the call can be routed to the wrong answering point, and assistance can be sent to the wrong location. Misleading or absent information for private systems has caused some documented emergency response problems and considerable concern, given expanded use of DPTS systems by organizations of all kinds.

Enhanced 911 can incorporate the locations of private system extensions into the system, but only if the owners upgrade their equipment to send the necessary signals and to create a callback path. The owners also must keep current location data for all the telephones in the system and input it into the E911 data base.

The 1998 General Assembly passed House Bill 560 to require the small number of dispersed private telephone systems that re-sell services to residential users to connect all their subscribers to the local Enhanced 911 emergency telephone system, beginning in 2001. HB 560 also established the DPTS /911 Task Force to study the costs to upgrade and connect existing systems to an E911 system, and to recommend whether owners and operators of private systems that were not covered by HB 560 should be required to take these steps. This summary presents the findings and recommendations of the task force. The following sections discuss a survey of problems caused by missing information from DPTSs; the cost of upgrading; actions taking by states and the Federal Communications Commission; and the task force recommendations.



## **Survey of Public Safety Answering Points, and Inventory of Private Multi-Line Systems**

The task force sent a survey to 97 PSAPs in November 1998, to obtain information about problems caused by missing information from private systems. Survey responses are discussed in Chapter 3, and the survey instrument is in Appendix B of the report.

The survey shows that only about 2% of 911 calls come from private PBX, Key, or Centrex systems (the three main types of DPTS systems). More than half of the responding PSAPs reported that, with PBX calls, they experienced a discrepancy between the displayed address and the actual location of the emergency at least once a month. The great majority of PSAPs, however, reported that these mismatches rarely if ever caused a mistake or delay in the dispatch. It also should be noted that most of the PSAPs do not keep data on call types or dispatch problems, so the answers were estimates.

It is important to know who will be affected by a change in law, but no one registers or keeps records on DPTS systems. The task force tried to determine how many private systems exist in the Commonwealth by polling Kentucky's 20 local exchange telephone companies. The companies reported 2,928 CENTREX systems, which operate much like PBX systems but are located in telephone central offices. The companies reported about 9,000 known Key and PBX systems, but asserted that the figures included only selected customers for whom data was available, and thus severely underestimate existing systems.

### **The Cost of Upgrading or Replacing DPTS Systems to Connect Fully with the E911 System**

The task force learned that upgrading existing private systems to transmit extension-specific information to the 911 answering center(PSAP) is neither simple nor cheap. One kind of DPTS, the Key system, does not track which extension seizes an outside line to make a call, so these systems cannot be upgraded to identify extensions for E911 purposes. PBX systems track the necessary information, but identifiers have to be converted to unique telephone numbers before they can be sent to a 911 center.

The task force obtained cost information from equipment vendors and from BellSouth, Kentucky's largest local exchange telephone company. It determined that the technology to upgrade a typical analog PBX unit of the smallest size (about 100 extensions) so that it will provide full connectivity to the E911 system will cost about \$14,200, plus an added monthly charge of \$565. Costs to upgrade a comparable digital unit are \$34,700 and \$2000 monthly. Estimates to replace a system also were made. The task force found that, given present technology, the costs of installing full E911

connections fall most heavily on the smallest systems, both because PBX upgrade costs do not increase in proportion to the number of extensions, and because Key systems, most commonly used in small applications, would have to be scrapped if the law required information for each extension.

### **State and National Activity on the Issue**

There are no federal standards for E911-compatible PBX equipment. The Federal Communications Commission (FCC) undertook to develop standards for multi-line equipment as part of an inquiry opened in 1994, but the 1996 Report and Order in that case dealt only with wireless E911 issues, leaving issues of wireline DPTS systems unresolved. To address the problem of DPTS/E911 compatibility, the National Emergency Number Association (NENA) has formed a subcommittee to study the issue. The study group's findings should be completed by September, 1999, and the resulting recommendations and model legislation are to be submitted to the FCC.

Five states have passed laws relating to private multi-line systems in E911 emergency service regions. Appendix C summarizes these laws. Representatives from Illinois and Washington, two states that have fairly comprehensive legislation on this issue, spoke to the task force. Illinois enacted broad requirements without prior study. Implementation has been very difficult, and the law has been amended several times since 1995 to exempt Key systems, move enforcement powers, and delay compliance deadlines. Washington, on the other hand, studied the issue before recommending legislation, and used its findings to design a more flexible law. Most small, compact systems were exempted, and the requirements for larger systems are linked to performance, not hardware. A statewide 911 coordinator works with DPTS owners and operators to increase awareness of the requirements and to develop a variety of alternate solutions.

### **Recommendations**

The task force adopted 11 recommendations, which comprise Chapter 6 of the report. Very briefly noted, the task force recommends that some systems - those that sell or resell local service - provide complete 911 information for all extensions. More flexible requirements are recommended for the vast majority of multi-line systems. Other recommendations include creation of a statewide 911 coordinator position, and new data collection requirements for PSAPs and others.

## CHAPTER I

### INTRODUCTION

HB 560, enacted by the 1998 General Assembly, requires that dispersed private telephone systems (DPTSs) connect into the local Enhanced 911 (E911) emergency telephone system, if one exists, beginning in 2001. This means the address of the telephone used to call 911, rather than just the address of the central switchboard, must be available to the person who answers the 911 call. It also means that the 911 center can call the originating telephone back if necessary. The requirements of HB 560 apply only to residential "joint tenant" systems, private systems that serve paying residential customers, as might occur in an apartment or assisted living complex.

HB 560 also established the DPTS/911 Task Force, and directed it to study "whether owners or operators of private systems should be required to locate their telephone extensions in order to operate effectively within an enhanced 911 emergency service." The group was asked to determine the costs, under a range of common conditions, of upgrading existing systems to connect to an E911 system. Based on its study of costs and potential benefits, the Task Force was asked to recommend changes, as appropriate, to the existing law.

This report represents the findings and recommendations of the 911/DPTS Task Force. The task force met six times. It heard testimony from telephone companies, Public Safety Answering Point (PSAP) administrators, officials from two states that are implementing laws on this subject, and businesses that use multi-line private systems. The task force surveyed local PSAPs to determine whether the lack of location data for private telephone systems causes significant emergency response problems, and obtained equipment cost data from several vendors. The recommendations of the task force comprise Chapter 6 of this report.

### Definitions

Any discussion of multi-line private systems or 911 telephone services requires specialized terminology, despite the authors' attempt to avoid jargon. The following list defines several acronyms and specialized terms used in the report.

*Adjunct Box, or Black Box:* Equipment attached to PBX by tie line which stores and transmits extension information to ALI database.

*ALI:* Automatic Location Identification. ALI is a feature of Enhanced 911 which allows the emergency call taker to receive extra information regarding the telephone from which the 911 call was placed. Additional information provided includes the name associated with and service address of the telephone placing the emergency call.

ANI: Automatic Number Identification. Identifies the telephone number placing the 911 call.

CAMA: Centralized Automatic Message Accounting. A type of signaling system used to carry caller identification over telephone lines.

Centrex: A private telephone switching system operated by a telco.

DID line: A line which allows for direct inward dialing.

DID trunk: Trunk from a central office which passes the last two to four digits of the Listed Directory Number to the PBX or hybrid phone system. The digits may then be used verbatim or modified by the phone system programming to be the equivalent of an internal extension.

DPTS: Dispersed Private Telephone System. In HB 560, DPTS was defined as a residential, shared tenant telephone system.

Enhanced 911 or E911: An advanced form of 911 service which not only identifies what telephone number placed the emergency call, but provides name and location information concerning the telephone which placed the call.

ISDN: Integrated Services Digital Network.

ISDN/PRI: A type of telephone signaling system which uses digital technology to carry information on telephone lines. Uses a signaling system that can carry more information than the older CAMA technology. Typically carries 64,000 bits of data per second and 23 voice channels simultaneously.

Key System: A privately owned telephone system in which telephones have multiple buttons, permitting the user to directly select central office phone lines and intercom lines. Common in small office settings.

PBX: Private Branch Exchange telephone system. A privately owned telephone switching system.

PRI: Primary Rate Interface. Used in conjunction with ISDN technology.

PSAP: Public Safety Answering Point. The location which answers emergency calls and dispatches assistance to those placing the 911 or E-911 call.

Shared tenant services: Centralized telecommunication services provided for compensation to tenants in a building or complex.

Telco: Short for telephone company. Any local exchange carrier.

### **Why is this an Issue?**

An "Enhanced" 911 emergency telephone system automatically identifies the telephone number from which a 911 call is made, and uses that number:

- a) to route the call to the proper PSAP; and
- b) to display pertinent information associated with that number when the call is answered by public safety personnel. The information that appears on the call-taker's screen includes the service address or other location of the telephone, and the public safety agencies that serve that location. The automated information can greatly expedite responses to emergency calls.

If a person dials 911 from an extension in a typical private multi-line system, one that has not been made E911-compatible, then the information on the call-taker's screen is for the main telephone number of the DPTS telephone system, not the extension. Typically, the address given is for the switchboard or switching equipment. The 911 center cannot call back the extension, only the switchboard. If the private system serves several locations, like different branch banks or schools or apartment units, then the call can be routed to the wrong PSAP, or assistance can be sent to the wrong location. PSAP administrators told the task force about several incidents of this kind that have occurred in Kentucky. In one case, police were sent to stop an armed robbery at a bank in Lexington. The robbery actually was underway at a branch in Nicholasville, but all the branches used a single PBX system. In another case, an ambulance was sent to the wrong plant in the wrong state, causing a considerable delay finding the person who actually needed help.

Ordinarily, trained call takers catch any discrepancies between the computer display and the caller's actual location. However, the enhanced information features are valued precisely because sometimes the caller cannot speak or cannot explain where he is, so a timely response depends on the automatically available information.

Calls to 911 in which the caller cannot describe his location are infrequent by all accounts, although no research was found to establish actual frequencies. These calls include such things as medical emergencies where the caller is incoherent or unable to speak, domestic disputes where the calling party cannot talk to the dispatcher, and calls made by children who cannot explain where they are.

### **Who is Affected?**

The task force was directed to study private telephone systems in areas with enhanced 911 emergency telephone service. An initial question was how many businesses, agencies, or other institutions fall into this category. While accurate information is not available, the following paragraphs provide several perspectives on the scope of this issue.

Not all parts of Kentucky are served by E911 systems, although the number of enhanced systems continues to grow. According to information provided by the Kentucky State Police, seventeen counties in the state have no 911 system at all. Residents in these counties must call the appropriate 7-digit number to reach the police, fire department, or other emergency service. Some other local PSAPs, and all answering services for cellular 911 calls, offer simple 911 service, and depend on the caller to give his or her location. Finally, part or all of 81 Kentucky counties have enhanced 911 (E911) services.

Private multi-line telephone systems include PBX (Private Branch Exchange) switching equipment that connects many telephone extensions to a limited number of outside lines. They also include simpler Key systems which cannot keep track of call paths; telephone-company-operated CENTREX systems, that perform many of the same

functions as a PBX located on the owner's premises; and some of the new entrants into the competitive local telephone market. The competitive carriers ("CLECS") provide telco services and must register with the Public Service Commission. Potential issues concerning these carriers were not addressed by the task force.

To get an estimate of the number of private systems that might be affected by stiffer requirements of E911 compatibility, the task force asked incumbent local telephone companies in the state to report the number of multi-line systems that operate within their service territories. The totals reported by the 20 local telcos are shown in Table 1.

TABLE 1

Number of Private Multi-line Telephone Systems in Use in Kentucky

<b>Lines to the Telco</b>	<b>PBX systems</b>	<b>CENTREX systems</b>	<b>Key systems**</b>
< 10 lines	1,039	2,345	5,588
10 - 100 lines	1,683	559	193
100 or more lines	55	24	2
<b>TOTALS</b>	<b>2,777</b>	<b>2,928</b>	<b>6,412</b>

\*\* BellSouth did not submit information regarding Key systems.

These numbers show that more than 12,000 multi-line systems are used by businesses, governments and other institutions in Kentucky. These figures severely under-report actual numbers, according to the respondents. BellSouth, the largest of the telcos, does not have the ability to identify operating Key systems. Most of the other companies reported only the PBX and Key systems that they themselves had sold or leased to customers.

Finally, despite the very large number of existing private multi-line systems, HB 560, as presently written, applies to only a few entities. At the first task force meeting, the three biggest telephone companies reported a total of only eight known residential shared tenant PBX systems in their service areas. These are multi-line systems that offer service to residential customers for a fee. Currently, they are the only ones that will have to identify every telephone extension if they operate within an enhanced 911 service area.

## CHAPTER II

### THE LIMITATIONS OF PRIVATE MULTI-LINE TELEPHONE SYSTEMS

Early on, the task force became aware that the process of transmitting location information from behind a PBX system is not just a matter of upgrading the private telephone system. The telephone system and how E911 functions within that system create many difficult engineering problems, incur additional costs to PBX owners, and makes solutions more cumbersome than is intuitively apparent.

#### How E911 Works

To better understand the problems presented by private multi-line systems within the E911 network, one must take a closer look at how the 911 system functions. Diagram 1 shows the elements of an E911 system. The telephones at the bottom of the diagram represent regular residential or business lines, while those at the top are extensions in a private, multi-line system.

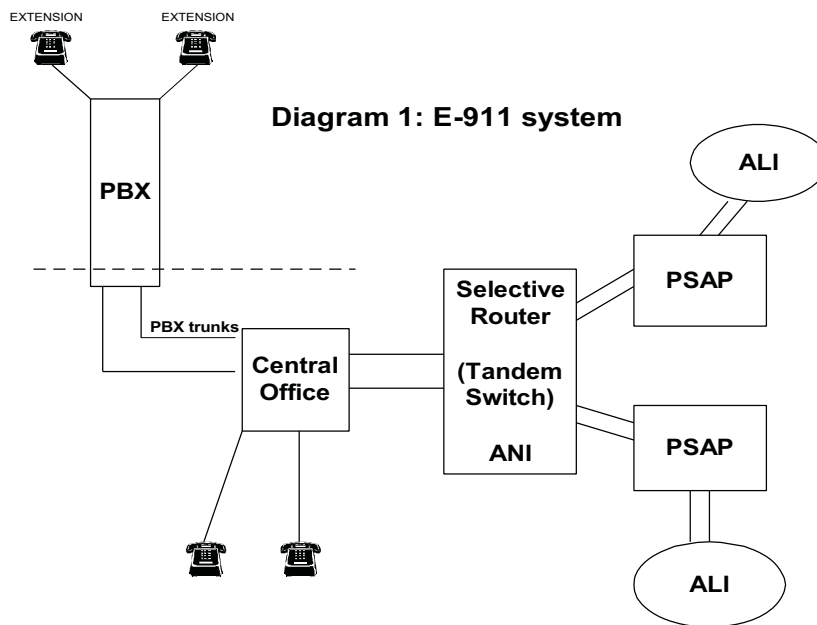

When a caller dials 911, the telephone company's central office recognizes an emergency call and routes it to a selective router, along with a CAMA signal that identifies the caller's telephone number. Forwarding the caller's number is referred to as Automatic Number Identification, or ANI.

The selective router uses the ANI information to determine which Public Safety Answering Point (PSAP) should receive the emergency call. Once this determination is made, the selective router selects the appropriate trunk connection and forwards the ANI information and the call to the correct PSAP.

The PSAP receives the call with specialized equipment that routes the ANI signal to a database of location information, retrieves the information for that number, and displays it on the dispatcher's terminal. The displayed information typically includes the address and location of the caller, type of service, i.e., residential, business, or PBX, and the names of public safety agencies that serve that location. This process is referred to as Automatic Location Identification (ALI).

The essential functions of an enhanced 911 system are:

- The call is automatically routed to the PSAP that serves the caller's location, identified by the caller's telephone number;
- Essential information about the caller's location, as identified by the telephone number, is displayed on a terminal at the PSAP; and
- The dispatcher knows the caller's telephone number, and can call back if the caller hangs up or he needs more information.

### **Problems Associated with PBX Connection to the E911 Network**

When a caller dials 911 from a station behind a multi-line system, that station is not identified separately by the ANI or ALI databases. Instead, information is transmitted only for the PBX trunk line, shown in Diagram 1. The core of the location identification problem stems from a PBX's inability to forward adequate and appropriate location information to the PSAP for use in emergency dispatch or to allow the PSAP to return a call to the originating station.

Most PBX systems can identify their extensions and could add an extension number to the signaling information they send with the call. However, the CAMA signaling system used to transmit the telephone number identification in 911 calls is limited in the amount of digit information it can send to the tandem switch and the PSAP. CAMA signaling cannot accommodate extra digits.

The PBX also acts as a barrier to the originating station if the PSAP needs to call back. Extension numbers are not included in ANI data. This would be a problem even if the extra digits could be transmitted over CAMA signaling. A call back to an originating station has to go through the switchboard and may be impossible after business hours.



## **Equipment Required to Upgrade Private Multi-line Telephone Systems**

The technical solution to identifying PBX extensions individually if they dial 911 requires that each extension be given a unique 7-digit number, and that number, rather than the PBX trunk line, be transmitted to the tandem switch and PSAP. These identifying numbers also have the ability to connect a call back to the right extension number if the PSAP needs to call back.

Present technology does offer potential solutions to the PBX extension location identification problem. The various elements needed to solve this problem are identified in Diagram 2. First, the PBX must be fitted with an adjunct box. This box functions as a database and transmits the number identification information for each extension, which the PBX owner must create and maintain for the system.

Next, at least two telephone lines that are used solely to carry CAMA signals (dedicated CAMA lines) must be attached from the adjunct box to the central office. These lines carry the extension's ANI information associated with the 911 call to the central office. The correct ANI information then can be transmitted to the selective router and on to the PSAP.

As an alternative, PBX systems that use ISDN/PRI technology can forward accurate ANI information using a different system of connection. These systems can attach a primary rate interface, or PRI, card to their systems which will allow complete ANI information to be forwarded. The PBX itself is connected to the central office by utilizing ISDN/PRI telephone lines, which allow the correct ANI information to be sent to the selective router and eventually the PSAP.

A PBX owner must also maintain accurate location information for each extension, and send this information to the service provider that maintains the ALI database, which is utilized by PSAPs which use E911 technology. This information must be updated each time an extension assignment is changed, so correct ALI information is available to the PSAP.

Finally, direct inward dialing (DID) telephone lines must be attached from the central office to the PBX to allow emergency dispatchers to call back the extension which dialed 911.

**Diagram 2:  
Elements needed for PBX upgrade**

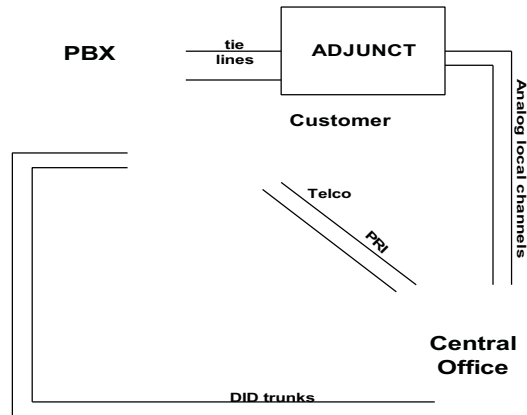
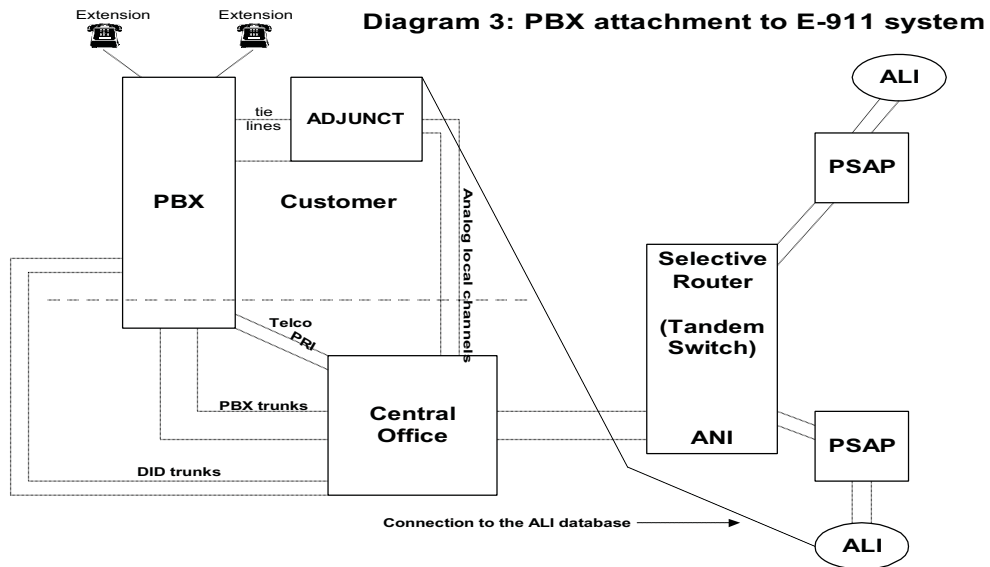

Diagram 3 adds the new elements shown in Diagram 2 to the basic E911 system of Diagram 1. It shows a PBX with the additional equipment necessary to send correct ALI information for each of its extensions connected to the E911 network.



## **CHAPTER III**

### **SURVEY OF PSAP EXPERIENCE WITH PRIVATE MULTI-LINE SYSTEMS**

A major topic of discussion by the task force during the first meeting in September 1998 was the experience of PSAPs and public safety agencies, such as police, fire, and ambulance, with 911 calls from PBX systems. The task force was presented with details of emergency events where the public safety agency responded to the address of the PBX switchboard, rather than the actual location of the emergency. It was noted that, though infrequent, these episodes represented potential disasters that could claim lives and property. However, task force members also were concerned about the huge expense of compliance with HB 560 to prevent such infrequent PBX address mismatches. Finally, this discussion resulted in questions from task force members, such as: "Is class of service displayed on the screen to alert dispatchers that they are dealing with a PBX system?" "Are dispatchers trained in handling PBX incoming calls?" and "Are there studies that track loss of property and life from these failed emergency events?" The answers were that class of service is displayed and dispatchers are trained to handle PBX situations; however, no studies or good data exist to supply statistics on any of these issues. As a result, it was agreed that the task force should gather information from PSAPs statewide on the nature of problems with PBX 911 calls, the extent of the problems, and how the PSAPs are affected.

#### **Survey of PSAPs**

The DPTS/911 Task Force sent out the survey to PSAPs in Kentucky in November 1998. The survey requested data limited to the previous twelve months, to lessen the chance of inaccurate estimates from PSAPs that do not track numbers or types of calls. Of 97 surveys mailed out, 58 were returned, a response rate of 59%.

The purpose of the survey was to determine the nature and extent of problems with 911 emergency calls from PBX environments. Of importance were such PSAP statistics as the annual volume of 911 and PBX 911 calls, the frequency of mismatches in PBX and location of emergency, misdirected and delayed dispatches resulting from these occurrences, and the extent to which this was perceived as a problem. In addition, pertinent open-ended comments were solicited from PSAP personnel. The data gathered would provide a broader picture of problems caused by the current situation, particularly PSAPs with E911 capabilities. A copy of the survey instrument comprises Appendix B of this report.

## **What Was Learned**

Results of the questionnaire, along with the comments added by respondents, were presented at the January meeting. Representatives from PSAPs in Louisville and Frankfort also spoke at the meeting. This section reports salient findings from the questionnaire, presentations, and the extensive discussion of these materials by members of the task force.

### **Survey Responses**

The first set of questions asked PSAPs how many 911 calls they received annually and how many of these were PBX calls, if their call takers could identify them. Thirty-five of 58 responding PSAPs reported that they received less than ten thousand 911 calls annually. Of the remaining 18 PSAPs, only 7 reported over 50,000 calls annually. PBX calls comprised about 2% of the total calls answered by the reporting PSAPs.

The Director of Communications, Louisville Division of Police, emphasized that not all calls to 911 are emergencies. He said true emergencies may be as few as 5% of the calls received. On the basis of his remarks, the number of actual PBX emergencies is probably much less than the 25,694 PBX calls reported by PSAP respondents.

PSAPs were also asked if they handled PBX 911 calls differently from other 911 calls. Nineteen of the 31 PSAPs that responded to this question said they handled PBX 911 calls differently. This general diligence was corroborated with comments such as: “Dispatchers are trained to recognize PBX calls and ask key questions...” or “We are aware that when PBX comes up on monitor we have to ask which branch or correct address.”

The central issue with a PBX system is that many telephone extensions or stations share a few telephone lines. So, when a 911 call comes through the PBX to the PSAP, the only address seen is the address of the PBX, not the location of the caller, who could be floors, buildings, or miles away. The survey attempted to determine how often this situation occurred, whether it was perceived as causing problems, and what actual delays or dispatching routing problems were experienced.

PSAPs were asked how many times in the past 12 months they received a PBX call in which the actual address of the emergency did not match that displayed on the PSAP’s system. Twenty-four of the 50 PSAPs that responded to this question said they rarely or never received a PBX call in which the actual address and displayed address were not matched, yet 21 reported mismatches at least twice a month. While more than five actual address and displayed address mismatches a month were reported by 6 PSAPs considered extra large (over 50,000 911 calls annually), 2 PSAPs considered small (less than 5,000

911 calls annually) also experienced more than five address mismatches monthly. Table 1 displays a breakdown of the data, showing the frequency of mismatches.

**TABLE 1.**

**Mismatch Between Actual and Displayed Address (past 12 months)**

Frequency of Mismatches	Number of PSAPs	Percent
Over 5 monthly	9	18
2 – 5 monthly	12	24
1 monthly	5	10
Rarely/Never	24	48
<b>Total</b>	<b>50</b>	<b>100</b>

Source: 1998 Survey of PSAPs

Next, PSAPs that indicated receiving wrong addresses from PBX 911 calls were asked whether there were instances in which this caused a problem. This question was intended to determine the proportion of PSAPs that had real or perceived potential problems with wrong addresses from PBX calls. Twenty-seven of the 48 PSAPs that responded to this question indicated that address mismatches had caused problems; only 12, however, reported that problems occurred at least monthly.

- Two specific aspects of the wrong address events were explored by asking PSAPs:
1. Whether the wrong address from a PBX call led to a dispatch to a wrong address, and how often; and
  2. Whether the wrong address from a PBX call caused a delay in dispatching, and how often.

Thirty-three out of 47 PSAPs responding to this question said they never had dispatched to the wrong address due to wrong automatic address information from a PBX call. Twenty-two of the 27 PSAPs that indicated the frequency of this problem said that it happened “rarely or never”.

More PSAPs seemed to indicate that the wrong address from a PBX call did cause delay in dispatching (19 of 46 responding) than actually dispatched aid to the wrong address (14 of 47 responding). So, it appears that when problems of this nature occur with PBX calls, the more common result is a delay in dispatch. A related problem brought out in the comments is that a PBX emergency call can be sent to the wrong PSAP because of the address mismatch. For example, both Prestonsburg and Floyd County operate PSAPs. Floyd County, which has numerous PBX systems, has had PBX 911 calls misrouted to the incorrect PSAP.

## **Evaluating Survey Responses**

Because records on details of 911 emergency calls are not routinely collected by most PSAPs, most responses to this survey were estimates. In addition, responses from a few PSAPs without E911 were included, although inclusion of these PSAPs would not change results.

Results of this survey can be interpreted differently, especially when either the data or PSAP comments are considered separately. Indeed, this occurred when the survey was presented to the task force. Based on comments elicited by the open-ended survey question, some task force members noted that there was reason to conclude that serious problems existed in PBX environments. Examples of comments that give this impression include: “We feel this situation is very serious and needs to be addressed”, “I believe something needs to be done to make certain the correct address or location is provided by the owners of PBX systems”, and “PBX systems do have potential to create life threatening problems”. However, other task force members emphasized the numerical responses and concluded that they showed a remarkable absence of actual PBX-related mishaps. At the January meeting, one task force member noted that concern over potential PBX problems was in fact the reason the task force was created. He said the survey was needed to measure the actual incidence and frequency of problems, not opinions. Some PSAP comments expressed the view that PBX systems cause no aggravated problems. For instance, one PSAP said “the system has worked very well.”

## **Related Issues**

The survey did reflect a problem with PBX systems, albeit the level of the problem is debatable. However, PSAP comments on the survey indicated that PBX systems present problems that pull in other issues. These include the need for more training, more public education, and more coordination between PSAPs and PBX facilities.

PSAP comments pointed to the need for trained dispatchers and coordination between public safety agencies and PBX owners as another related issue. In his presentation before the task force, the Director of Louisville’s Division of Police emphasized the importance of dispatcher training, retention, and the need for dispatchers who are long-term local residents. One PSAP comment says that, “Good 911 operators and good training can overcome most of the problems, with the exception of callers unable to speak”.

The Director of Communications for the Louisville Division of Police highlighted the importance of public education on what is considered an actual emergency and the need to dial 911 only for such events. He presented figures in the January meeting, showing that only one third of his PSAPs’ emergency calls came on 911 telephone lines;

the other two thirds were made through regular 7-digit phone lines. At the same time, he reported that many callers use 911 for non-emergency matters.

A comment that shows the effectiveness of coordination between the PBX owner and PSAPs says, “PBX systems do cause some problems on call backs on bank robber alarms. However, we contacted the banks and they provided direct numbers to each bank to us to use and we programmed them into our CAD (Computer Assisted Dispatch) system”. This comment shows the importance of coordination and identifies the need to classify PBX environments. Some PBX environments, such as banks and public schools, appear with some consistency in the comments.





## CHAPTER IV

### ESTIMATION OF DPTS SYSTEM UPGRADE COSTS

A decision to require private multi-line systems to adapt their extensions for E911 purposes involves significant costs and benefits. The preceding section that reported survey results presents part of the debate on this matter.

This section develops estimates of the minimum costs of complete integration between a PBX and E911 system. This means complete provision of ANI, ALI, and call-back to every extension. The task force also discussed alternate ways to comply, such as a dedicated computer on location that printed a room number involved in the emergency. The cost for the total solution, however, applies to covered entities as the law currently is written, and represents an important benchmark. These cost estimates apply to basic PBX units with capability of 100 or fewer stations. However, other equipment, such as Centrex systems and Key systems, are excluded. Centrex systems are not entities covered under the current law. Technology for Key systems solutions is still unavailable.

For cost and technical information, the task force surveyed two PBX vendors (Lucent and Nortel), two vendors of ALI solutions (Telident and Proctor), and a representative telco (BellSouth). BellSouth's telephone connectivity costs are assumed in this section to be representative of charges that apply across the state.

The minimum one-time cost for upgrading an analog PBX unit is approximately \$14,200.00, with a \$565.00 monthly fee. Equivalent costs for a digital PBX unit are \$34,700.00, with a \$2,001.00 monthly fee. These costs are between \$10,000.00 and \$40,000.00, according to testimony presented by the State Administrator for the Washington State E911 office before the task force in February, 1999.

#### Cost Variables

The level of technology of the existing PBX unit and of the local phone system are important determinants of the available solutions. Elements of these two systems present different challenges and, ultimately, different costs. Some of the variables that affect costs are:

(1) PBX Type and Model

There are several different PBX, Key systems, and hybrid systems on the market today. Many other types of DPTS systems are already in use by PBX owners, and some of the manufacturers of these systems have gone out of business. This can present update problems, since all DPTS systems have the same goal but differing equipment specifications. Also, whether a DPTS system uses Analog or Primary Rate Interface (PRI) technology can effect upgrade requirements and costs. Since

most DPTS systems in use are equipped with analog technology, most of the equipment vendors contacted provide only analog solutions. Both PRI (digital) and analog DPTS systems are presently used in Kentucky.

(2) Number of Extensions

This refers to the number of station lines or extensions which are in use behind the DPTS system. ALI solutions are usually customized around the number of station lines or extensions used by the system. This number can range from about 250 to over 70,000. ALI solutions for DPTS systems with fewer than 250 extensions are available, at the same cost as the minimum 250.

(3) Number of DID and non-DID lines

Each department or cluster of station lines must be identified by at least one DID line. Where no DID lines are available, non-DID lines must be converted to 7-digit numbers to serve the function of DID lines.

(4) Interconnection requirements of the local telco

If an independent vendor is providing a DPTS solution, it is necessary that the vendor and the local telco be capable of interfacing with each other.

(5) Number of Ports on the PBX machine

Most solutions require 2-wire analog circuits connecting to the 911 Tandem switch.

### **Cost Components**

The term components of costs refers to pieces of hardware, software, or services that are needed to upgrade a PBX. Cost components can be placed into the following categories:

1. Connectivity: The cost of connectivity refers to the private line channels which connect from the PBX adjunct box directly to the telco's E911 tandem switch. These costs are tied to telephone company tariffs. Each item and service a telco offers must have an accompanying tariff filed with the Kentucky Public Service Commission, which lists in detail the specifications and accompanying cost for each item. Costs for network connections, which enable DPTS systems to transmit ANI data, are established by the telcos in their tariffs. These costs are non-negotiable. The kinds of connections will also depend on whether an analog or Digital PBX unit is currently in use.

2. Upgrade: This consists of the adjunct box and the DID trunks and numbers that are required to upgrade analog PBX units. Digital PBX units require a PRI interface card and software.

3. Replacement of PBX unit: In some cases, it may be impractical or impossible to retrofit an older PBX or existing Key system, so a whole new unit is needed.

4. Database creation/upkeep: The ALI database contains the name and address information associated with each telephone number, and is usually created and maintained by or under contract with the telco. Since most telcos restrict access to their databases, ALI database creation and management at present is a service only telcos can provide. There are companies which market these services, and which might offer them at lower cost, but it may not be possible for a PBX owner to contract this service, due to the restrictions placed on the ALI databases by telcos. To the extent that competitive vendors are granted access to the ALI records, the costs associated with database maintenance may decrease.

5. Database administration: The PBX owner is responsible for tracking any changes in his organization and transmitting these changes in a standard format to the telco.

Minimum cost estimates for complete technical solutions are shown in Table 1 and Table 2. Two different cost estimates are displayed. Table 1 shows costs associated with upgrading analog and digital PBX systems. Table 2 displays costs for replacing aging systems with a new analog or digital PBX system, respectively.

The minimum costs displayed apply to systems with 100 and up to 500 extensions. Examples of such small to mid-sized PBX environments include hospitals, high schools, community colleges, retirement homes, and small businesses.

The costs of connecting to a telco are in fact the costs presented to the task force representing the tariffed charges that apply in BellSouth's territory. Hence, costs can range higher for upgrading larger PBX systems and may be different in areas served by other telephone companies.

The tables do not include database administration costs that can be incurred by PBX owners. These costs can vary, depending primarily on company size, frequency of change in phone extensions, and employee availability for database maintenance. The only quantifiable cost the PBX owner will incur is the purchase of a dedicated 486 or better, Y2K-compatible PC for storage of data.

The main cost components in upgrading are : Connectivity, Upgrade with adjunct box, and Database creation and maintenance. Table 1 displays costs for both analog and digital PBX units. There are one-time costs (labeled "once") and monthly costs for the duration of the 60-month contract with BellSouth, on which these estimates are based. The minimum one-time upgrade cost for analog systems is \$14,200, with a recurring monthly fee of \$565; the minimum one-time upgrade cost for digital systems is \$34,700, with a recurring monthly fee of \$2,001.

Although the digital PBX unit has newer technology, it has yet to supplant the very common analog system that has been the standard for many years. Moreover, digital technology was not developed in direct response to the E911 problem of PBX units. This is one reason digital update costs are higher.

**TABLE 1A**

**Minimum Costs to Upgrade Analog PBX**

	CONNECTIVITY		UPGRADE		DATABASE		Total For Upgrade
	2 dedicated lines from Adjunct Box to Telco Central Office		Adjunct Box 10 DID Trunks 100 DID #s		Creation & Upkeep by Telco		
	Once	Monthly	Once	Monthly	Once	Monthly	
ANALOG	\$600	\$110	\$10,000	\$260 \$17	\$3,600	\$178	
INITIAL TOTALS	<b>\$600</b>		<b>\$10,000</b>		<b>\$3,600</b>		<b>\$14,200</b>
MONTHLY TOTALS		<b>\$110</b>		<b>\$277</b>		<b>\$178</b>	<b>\$565</b>

**TABLE 1B**

**Minimum Costs to Upgrade Digital PBX**

	CONNECTION		UPGRADE		DATABASE		Total for Upgrade
	1 ISDN/PRI line		1 PRI interface card & software		Creation & Upkeep by Telco		
	Once	Monthly	Once	Monthly	Once	Monthly	
DIGITAL	\$1,110	\$1,823	\$10,000 \$20,000		\$3,600	\$178	
INITIAL TOTALS	<b>\$1,110</b>		<b>\$30,000</b>		<b>\$3,600</b>		<b>\$34,700</b>
MONTHLY TOTALS		<b>\$1,823</b>				<b>\$178</b>	<b>\$2,001</b>

Some owners may decide to upgrade with a new PBX unit. The first part of Table 2 reflects costs of upgrading with a new analog PBX unit, although most vendors contacted recommended replacing with a digital rather than analog PBX unit. The second part of Table 2 displays costs for upgrading with a new digital PBX unit. Initial minimum costs for this option are highest, due to the cost of the PBX unit. However, this equips the owner with technology that goes beyond the E911 solution. The minimum one-time cost to replace and upgrade an analog system is \$34,200, with a recurring monthly fee of \$565; the minimum one-time cost to replace and upgrade a digital system is \$54,710, with a recurring monthly fee of \$2,001.

**TABLE 2A  
Minimum Costs to Replace & Upgrade Analog PBX**

	CONNECTION		NEW PBX		DATABASE		TOTAL
	2 dedicated lines from Adjunct Box to Telco Central Office		PBX 10 DID Trunks 100 DID #s		Creation & Upkeep by Telco		
	Once	Monthly	Once	Monthly	Once	Monthly	
ANALOG	\$600	\$110	\$30,000	\$260 \$17	\$3,600	\$178	
<b>INITIAL TOTALS</b>	<b>\$600</b>		<b>\$30,000</b>		<b>\$3,600</b>		<b>\$34,200</b>
<b>MONTHLY TOTALS</b>		<b>\$110</b>		<b>\$277</b>		<b>\$178</b>	<b>\$565</b>

**TABLE 2B  
Minimum Costs to Replace & Upgrade Digital PBX**

	CONNECTION		NEW PBX		DATABASE		TOTAL
	1 ISDN/PRI line		Purchase of new digital PBX system		Creation & Upkeep by Telco		
	Once	Monthly	Once		Once	Monthly	
DIGITAL	\$1,110	\$1,823	\$50,000		\$3,600	\$178	
<b>INITIAL TOTALS</b>	<b>\$1,110</b>		<b>\$50,000</b>		<b>\$3,600</b>		<b>\$54,710</b>
<b>MONTHLY TOTALS</b>		<b>\$1,823</b>				<b>\$178</b>	<b>\$2,001</b>

## **Conclusion**

Given present technology, installing full E911 connections to PBX systems falls most heavily on the smallest systems, since costs do not increase in proportion to the number of extensions. The disproportionate costs to small private systems is even more apparent when one remembers that Key systems rather than PBXs are used in many small offices. These cannot be upgraded to link extension information to a 911 call. If full E911 connectivity is required for such offices, these systems would have to be replaced completely.

## CHAPTER V

### STATE AND FEDERAL ACTION ON DPTS INTERFACE ISSUES

The problems surrounding DPTS system interface within the E911 network is a familiar one at both the state and national level. Although the problem is widespread, few states have addressed this issue. Even fewer states have attempted to enact comprehensive legislation to correct the problem, citing the lack of uniform federal standards for DPTS equipment as an insurmountable difficulty.

During the course of investigation, task force staff inventoried state legislation and national activity regarding DPTS system interface issues. A few individual states have attempted legislative action to address the location identification problems associated with multi-line private telephone systems. The following is a summary of laws of five states addressing the problem, and recent federal action on this subject.

#### **State Action Regarding PBX Systems**

Connecticut enacted legislation to resolve the extension location identification issue. Rather than mandating any technical solution for multi-line systems, Connecticut's law requires municipalities to file a PBX 9-1-1 utilization plan with its Office of State-wide Emergency Telecommunications before installing E911 service in that area.

In contrast to Connecticut, Illinois enacted a comprehensive bill. Illinois' legislation, as originally passed, required that all PBX, Centrex, and some specifically defined Key systems provide location identification for every extension. The law requires these systems to forward the telephone number, extension number and physical location of the source of the emergency call. The law does exempt wireless PBX systems. Since its enactment in 1994, the law has been amended several times, amid much debate.

Mississippi's legislation deals specifically with shared tenant services, or privately owned switch systems which resell telephone service to end users. The statute requires that all shared tenant service providers be E911 compatible, meaning that they must provide correct location identification information for all end users. The law also requires all service suppliers to comply with the National Emergency Number Association (NENA) data transmission and operational standards by the effective date of the statute.

In 1993, Texas enacted legislation regarding only residential shared tenant service providers. The law requires residential shared tenant service providers to transmit location identification information for all end users. The statutes are enforced on the local level by Texas' twenty-four Councils of Governments scattered throughout the state.

Finally, Washington has enacted legislation regarding this issue. The law requires residential, business, and school multi-line switch systems to forward physical location information for the extension placing the emergency call. For businesses, the statute applies only if the system serves a physical area exceeding 25,000 square feet, locations on more than one floor, or multiple buildings. Although the requirements cover most multi-line systems operating in Washington, the law as written allows multi-line telephone system operators to use innovative, less technical solutions to the location identification problem.

### **National Activity Regarding the Issue**

In 1994, the Federal Communications Commission (FCC), in CC Docket #94-102, was charged with the task of wading through the issues surrounding PBX and wireless standards for interface which would allow location identification information to be forwarded within the E911 network. This inquiry resulted in the Report and Order and Notice of Further Proposed Rulemaking for CC Docket No. 94-102, which was adopted June 12, 1996. This Order set standards for wireless E911 interface, but the PBX standards were not addressed. To date, the FCC has not revisited the PBX issue.

The National Emergency Number Association (NENA) has formed a Private Switch Subcommittee to study E911 interface problems with private multi-line telephone systems. The subcommittee includes representatives from emergency services, telcos, telecommunication equipment vendors and others. The final report and model legislation developed by this subcommittee will be forwarded to the FCC in September.

### **A Closer Look: The Illinois and Washington Examples**

Illinois and Washington have implemented fairly comprehensive legislation on this issue. In February, the task force invited representatives from these two states to address the task force concerning each state's enacted legislation. Ms. Deborah Prather, 911 Director for the Illinois Commerce Commission, and Mr. Norman Forshee, St. Clair County, Illinois E911 Coordinator, provided testimony to the task force regarding DPTS legislation in Illinois, and issues with implementation of the law in that state.

### **The Illinois Experience**

Ms. Prather provided an update on the implementation of the Illinois statute via teleconference with the Task Force during the February 1999 meeting.



As a state that did not study the issue prior to taking action, Illinois enacted a broad bill that included multi-line systems without regard to size or type of business. The initial comprehensive design of the bill has led to implementation problems.

Many businesses have complained about compliance costs and arbitrary deadlines. Some businesses that have complied with the law worry about subsequent liability, which they seek to limit through a certification process. Yet others, with on-site emergency services, question the necessity of compliance.

Telcos have largely interpreted the law to mean that a telephone number (plus DID capability) must be assigned each extension of the PBX. Therefore, the lack of a specific definition for "physical location" requires an excessive use of DID numbers, adding to problems with the numbering system.

The Illinois bill has been amended to exempt Key systems, to move enforcement from the telcos to the Office of the Attorney General, and to postpone the compliance date to June 30, 2000 for entities operating a private switch installed before June 30, 1996.

### **The Washington Experience**

Mr. Bob Oenning, State Administrator for the Washington State E-911 Office, appeared before the task force, describing the process utilized by Washington before legislation was attempted, how the legislation has been implemented, and the success Washington has experienced regarding compliance with the DPTS laws.

Washington began the process by establishing a task force to study the E911/DPTS interface issue. The PBX Work Group reported to the Washington State E-911 Advisory Committee on September 23, 1993. The work group's report encompassed several recommendations, which were incorporated into legislation filed and passed during Washington's 1995 legislative session.

The Washington work group was comprised of representatives from fire, police, business, telephone companies, and telecommunications consultants. Anyone desiring to address this issue was invited to give presentations. Governmental agencies, business community members, tenant service owners, school system telecommunication administrators, telephone companies, and PBX manufacturers all presented their ideas and concerns to the group. The group also surveyed PBX manufacturers and PBX owners regarding this issue.

The Washington group made several discoveries during its investigation. First, most regulatory agencies in Washington were not aware of the DPTS/E911 interface problem. Once the problem was brought to their attention, they adopted emergency rules

to require telephone companies to provide interface solutions on the telco side of the network immediately. Next, the work group realized that businesses in Washington could be separated into two basic categories: large and small. There were few businesses that fell in-between these two categories. Small businesses, which operate in localized office spaces, were not a problem at all. Large businesses which operated in large, spread out buildings, or in several different locations presented a very complex problem within the E911 system. The group discovered that the key to the problem is the way in which the PBX is being used, and that the relationships inherent in the location of use have a significant impact on the urgency for a PBX interface solution.

The work group also discovered that no accurate information was available regarding the actual number of PBX, Key and hybrid systems in Washington. Local exchange carriers were unable to gather information beyond the type of service they provided their users, so they could not provide the requested information. Perceived PBX owners were sent surveys by the work group, but response rate was low, leaving the resulting data less than accurate. This presented a problem for the work group. No estimate could be made for the number of residential and business DPTS systems that would have to comply with enacted legislation. Ensuring compliance among an unknown group of DPTS owners would be difficult.

Another issue evolved regarding DPTS equipment. PBX manufacturers had no real economic incentive to modify their PBX equipment to insure interface with the E911 network. Also, no useful equipment standards for PBX interface with the E911 network have been created to set guidelines for PBX system manufacturers to follow. With no economic incentive or useful standards, PBX manufacturers selling systems in Washington simply chose to maintain the status quo set by their industry.

Following its investigation, the work group presented recommendations to the Washington State E-911 Advisory Committee. The advisory committee presented the recommendations to the state legislature, which incorporated them into a bill which was passed in Washington's 1995 legislative session. The bill required residential PBX systems to provide ANI and ALI data for any residential unit that dialed 911. It also required business PBX systems subject to the provisions of the law to provide number and location identification for all extensions. This requirement was limited to businesses containing a physical area exceeding 25,000 square feet, businesses located on more than one floor, office buildings utilizing PBX systems to service more than one business, or businesses having multiple locations. Finally, the bill required both common and public schools in Washington to forward location identification information for their extensions. The bill encouraged Washington's State E-911 program to develop an educational program for PBX owners and empowered the state Director of Fire Protection Services to adopt rules on the sufficiency of location information requirements.

In conjunction with the Washington legislation, the Washington State E-911 office has been active in requesting the FCC to set equipment and network standards to help facilitate a solution to the PBX problem. The office has published guidelines for

equipment capabilities to help businesses understand what they need to upgrade to comply with the law, and they are aiding PBX owners with implementation of solutions. Local fire services are authorized to approve PBX upgrades and are directed to verify location identification information. A certification process has been implemented in conjunction with the law and has proven to be very beneficial in encouraging compliance throughout the state. According to Mr. Oenning, the Washington legislation has been very successful.

To ease compliance with the Washington legislation, the state has allowed innovative solutions to resolve the location identification problem. For example, schools have installed pay phones which are available for use both during school hours and after hours, in case of an emergency. Since the pay phone uses a single telephone line, emergency calls placed from the phone can be easily located. Also, companies that operate in multi-level buildings or in large areas have been allowed to pool telephone extensions for location purposes. When 911 is dialed from these grouped extensions, the call is routed through an individually installed trunk and then on to the PSAP. The trunk is tagged with the location within the building where these grouped extensions are located.



## CHAPTER VI

### DPTS/911 TASK FORCE RECOMMENDATIONS

The task force members believe it is important to work towards an ideal situation, where every 911 call reaches the right PSAP, and where the call taker at a PSAP with enhanced capabilities has access to sufficient information to handle the call. The members also believe that mandating expensive equipment is not the only solution. Washington State's experience shows that imaginative, cost-effective solutions can be found if the law allows flexibility and if parties work together.

The recommendations below require that some systems - those that sell or resell local service - provide complete 911 information for all extensions. The vast majority of multi-line systems have more flexible requirements, which could be met using combinations of technology, employee training, and coordination with public safety agencies and the PSAP.

1. The Task Force recommends retaining the provisions of the 1998 legislation that require complete E911 connectivity for residential shared tenant telephone systems. The provisions should be amended to change the compliance date to January 1, 2003, or two years after E911 service is implemented in the locality, whichever is later.
2. The Task Force recommends requiring complete E911 connectivity for all business shared tenant telephone systems by January 1, 2003, or 2 years after E911 service is implemented in the locality, whichever is later.
3. The Task Force recommends lesser location identification requirements for all other private multi-line telephone systems. Multi-line telephone systems serving multiple locations or serving buildings larger than 25,000 square feet should provide location identification information that identifies individual buildings, and floor and wing of the larger buildings. Facilities with a 24-hour security force should be excluded from the requirement. The security force should be trained to meet Public Safety Personnel and guide them to emergency sites. Exempted facilities should be required to file a location identification plan with the PSAP servicing the facility, as discussed in Recommendation #5.
4. The Task Force recommends, unless otherwise indicated, that all private multi-line telephone systems comply with Recommendation #3 by January 1, 2003, or 2 years after E911 service is available in the locality, whichever is later.
5. The Task Force recommends that by January 1, 2001, all multi-line telephone systems operating in jurisdictions where E911 service is available must develop a location identification plan with local public safety officials and the PSAP which serves that location. The plan should include a detailed map of the facility, location information for

all extensions, detailed instructions for PSAP dispatch, and information regarding employee safety and security training. This filed information should be exempted from request through the Open Records Law.

6. The Task Force recommends that any entity providing telephone service and any vendor selling private multi-line telephone system equipment should cooperate fully with PSAPs and the statewide 911 coordinator to identify businesses with private multi-line telephone system equipment. All entities providing telephone service and all vendors of private multi-line telephone system equipment should maintain statistical data regarding the location of private multi-line telephone system equipment.

7. The Task Force recommends that any new private multi-line telephone system serving multiple locations or serving buildings larger than 25,000 square feet, purchased and installed after January 1, 2001, or 2 years after E911 service is available in the locality, be required to be E911 compatible, whichever is later.

8. The Task Force recommends the establishment of a statewide 911 coordinator. The coordinator should provide guidelines for evaluations of multi-line telephone system compliance and implementation strategies. The coordinator should also provide education, training, and technical assistance for PSAPs and private multi-line telephone system owners and operators. The coordinator should develop a location information waiver system for private multi-line telephone systems. The coordinator should assess private multi-line telephone system equipment and technological advancements and forward recommended modifications to compliance requirements to the Legislative Research Commission by August of each year preceding the regular session for referral to the appropriate committee.

9. The Task Force recommends that multi-line telephone systems designated as Key systems be exempted from all requirements, with the exception of Recommendation #5.

10. The Task Force recommends that PSAPs maintain statistical data regarding the incidence of incorrect dispatch caused by incorrect ALI data or any other data required by the statewide 911 coordinator, as established by regulation. PSAPs should report this information to the statewide 911 Coordinator, as established by regulation.

11. The Task Force recommends that any entity providing telephone service should provide full 911 and/or E911 connectivity to customers in jurisdictions where Telcos provide 911 services. These entities should be required to collect and remit all appropriate fees. The subscriber line fee sections of the 1998 legislation should be amended to clarify who collects the fee, who remits the fee, and to whom.

12. The Task Force recommends reviewing the 1998 legislation and amending where necessary. The definitions section should be amended to meet telecommunication industry standard equipment definitions for PBX and SIN, and to refine the definition of PTS. Also, the requirement to forward the number of trunks used by a DPTS should be deleted.

**APPENDIX A**  
**HOUSE BILL 560**





AN ACT relating to telecommunications.

***Be it enacted by the General Assembly of the Commonwealth of Kentucky:***

Section 1. KRS 65.750 is amended to read as follows:

As used in ***this section to*** KRS ~~[65.755 and]~~ 65.760, ~~[,]~~

***(1)*** "911 emergency telephone service" means a telephone service which provides the user of the public telephone system the ability to reach local emergency service agencies on a twenty-four (24) hour basis, by dialing the digits 9-1-1. Such a service is capable, at minimum, of transmitting requests for law enforcement, firefighting, and emergency medical and ambulance services to a public safety agency or other provider that provides the requested service at the place where the call originates. A 911 emergency telephone service may also provide for other emergency services;

***(2)*** *"Automatic number identification (ANI)" means a feature that allows for the automatic display of the ten (10) digit number, or equivalent, used to place a 911 call;*

***(3)*** *"Automatic location identification (ALI)" means a feature by which the name and address associated with the calling party's telephone number is made available to a PSAP;*

***(4)*** *"Automatic location identification data management system (ALI/DBS)" means a system of manual procedures and computer programs used to create, store, and update the data required for ALI in support of enhanced 911;*

- (5) "Dispersed private telephone system (DPTS)" means a multiline, shared tenant system or PBX used for the purpose of reselling telephone service to residential customers and whose connection to a telephone network is capable of carrying emergency calls from more than one (1) specific location within a structure or structures but does not mean a multiline, shared tenant system or PBX owned and operated by a state agency or used in providing service within a hotel or motel;
- (6) "Fully enhanced 911 emergency telephone service" means a telephone network feature that selectively routes calls placed to the national 911 emergency number to the proper public service answering points (PSAPs) and provides the PSAP with a voice connection and ANI and ALI information;
- (7) "Private branch exchange (PBX)" means a privately owned switch system that connects calls to a telephone company;
- (8) "Public safety answering point" or "PSAP" means a communications facility that is assigned the responsibility to receive 911 calls originating in a given area and, as appropriate, to dispatch public safety services or to extend, transfer, or relay 911 calls to appropriate public safety agencies;
- (9) "Service supplier" means a person or entity that administers, maintains, and operates the ALI/DBS and may include telephone companies that provide local exchange telephone service to a telephone subscriber; and
- (10) "Station identification number (SIN)" means a number that a DPTS uses to identify a specific station on the switch.

SECTION 1. A NEW SECTION OF KRS 65.750 TO 65.760 IS CREATED TO  
READ AS FOLLOWS:

(1) Any DPTS located in an area that has adopted enhanced 911 emergency service shall within three (3) years of the date of its adoption, or if already adopted within three (3) years after the effective date of this Act, be able to:

(a) Operate effectively within an enhanced 911 system;

(b) Transmit a SIN for the station that directly dials the emergency number 911 to the service supplier; and

(c) Provide the service supplier with the following system information that shall be updated within five (5) business days if changes occur within the system:

1. Number of incoming trunk connections to the enhanced 911 system;

and

2. SIN, sublocation, such as floor or apartment number, if applicable, and street address of each station that may originate an emergency call.

(2) In areas where fully enhanced 911 service has been implemented, the service supplier shall, at a minimum, make the verified ANI and ALI provided by the DPTS available to a PSAP for a fully enhanced 911 call.

(3) In areas where fully enhanced 911 service has been implemented, the service supplier shall maintain the confidentiality and privacy of all information contained in the ALI/DBS, including any information that identifies telephone

calls made from extensions on DPTS, except when the release of the information is ordered by a court of competent jurisdiction.

(4) In areas where enhanced 911 service has been implemented, an employee of a PSAP shall not retrieve or disclose ALI information except in response to a 911 call or for the purpose of maintaining the ALI database, unless ordered by a court of competent jurisdiction.

SECTION 2. A NEW SECTION OF KRS 65.750 TO 65.760 IS CREATED TO READ AS FOLLOWS:

(1) Any owner, employee, or agent of a DPTS that knowingly or wantonly violates the provisions of subsection (2) of Section 2 of this Act shall be fined not less than twenty-five dollars (\$25) nor more than two hundred dollars (\$200) or imprisoned in the county jail for not more than ninety (90) days, or both. Each day the violation continues shall be considered a separate offense .

(2) Any owner, employee, or agent of a DPTS or a service supplier that violates the provisions of subsection (3) of Section 2 of this Act shall be subject to the following penalties:

(a) For a first offense, a Class A misdemeanor; and

(b) For a second and subsequent offense, a Class D felony.

Section 3. KRS 65.760 is amended to read as follows:

(1) Any city, county, or urban-county government may establish 911 emergency telephone service upon approval of the governing body of the city, county, or urban-county

government, and may adopt regulations concerning the provision of this service by ordinance.

(2) Any city, county, or urban-county government, or any combination thereof, may with the approval of their governing bodies enter into an interlocal cooperation agreement creating a joint 911 emergency telephone service.

(3) The funds required by a city, county, or urban-county government to establish and operate 911 emergency telephone service, or to participate in joint service with other local governments, may be obtained through the levy of any special tax, license, or fee not in conflict with the Constitution and statutes of this state. The special tax, license, or fee may include a subscriber charge for 911 emergency telephone service that shall be levied on an individual exchange-line basis, limited to a maximum of twenty-five (25) exchange lines per account per government entity. Any private commercial telephone service or owner of a dispersed private telephone system (DPTS) that provides local and 911 emergency service to subscribers for compensation shall collect and remit the subscriber charge to the local government on the same basis as the primary local exchange carrier, except that this requirement shall not apply to a state agency that currently maintains an independent 911 system with its own public safety answering point ~~[to be collected from local exchange telephone subscribers in the area to be served by 911 service on an individual exchange line basis limited to a maximum of twenty five (25) exchange lines per account]~~. All revenues from a tax or fee expressly levied to fund 911 emergency services shall be expended solely for the establishment, operation, and

*maintenance of a 911 emergency communications system; this may include expenditures to train communications personnel and to inform the public of the availability and proper use of 911 service*<sup>[this purpose]</sup>.

(4) The governing body may apply for and accept federal moneys, and may accept contributions and donations from any source for the purpose of funding 911 emergency telephone service.

~~(5)~~<sup>(4)</sup> Nothing in this section shall preclude other means of establishing or funding a 911 emergency telephone service within any local area or exchange, nor require the operation of such service by any local government.

Section 4. There is hereby established the DPTS/911 Task Force to study the issue of whether owners or operators of a dispersed system should be required to locate their telephone extensions in order to operate effectively within an enhanced 911 emergency service. The task force in its study shall determine the cost, under a range of common conditions, of purchasing or upgrading the equipment and services necessary to transmit the full 10-digit identifying number to a service supplier. The task force shall report its findings together with specific legislative recommendations, if applicable, to the Legislative Research Commission and to the interim committee with jurisdiction over matters concerning telecommunications services no later than August 1, 1999.

Section 5. The task force shall consist of no more than fifteen (15) members appointed by the Legislative Research Commission on or before July 1, 1998. Members shall include at least four (4) members of the General Assembly and nonlegislative members representative of business, emergency services, communications providers,

industry, and other stakeholders in the issue. The Legislative Research Commission shall appoint the chair or co-chairs of the task force, who shall be members of the General Assembly.

Section 6. Staff services to be utilized in completing this study are estimated to cost \$20,000. These staff services shall be provided from the regular Commission budget and are subject to the limitations and other research responsibilities of the Commission.





**APPENDIX B**

**THE 1998 PRIVATE BRANCH EXCHANGE (PBX) SURVEY**



**THE 1998 PRIVATE BRANCH EXCHANGE (PBX) SURVEY**

1. How many 911 calls do you receive annually?

<i>Minimum</i>	<i>Maximum</i>	<i>Average</i>
200	800,000	46,584
<i>Number of PSAPs Responding</i>		<i>Percent of Respondents</i>
<u>17</u>		<u>30.9%</u> Documented count
<u>38</u>		<u>69.1%</u> Estimated count

2. Can your call takers identify PBX 911 calls?

<i>Number of PSAPs Responding</i>	<i>Percent of Respondents</i>
<u>28</u>	<u>52.8%</u> Yes
<u>25</u>	<u>47.2%</u> No

3. If yes, how many PBX calls do you receive annually?

<i>Minimum</i>	<i>Maximum</i>	<i>Average</i>
10	8,500	1,117
<i>Number of PSAPs Responding</i>		<i>Percent of Respondents</i>
<u>1</u>		<u>3.8%</u> Documented count
<u>25</u>		<u>96.2%</u> Estimated count

4. Do you handle PBX calls differently than other 911 calls?

<i>Number of PSAPs Responding</i>	<i>Percent of Respondents</i>
<u>19</u>	<u>61.3%</u> Yes
<u>12</u>	<u>38.7%</u> No

5. How many times in the past 12 months did you receive a PBX call in which the actual address of the emergency did not match that displayed on your system?

<i>Number of PSAPs Responding</i>	<i>Percent of Respondents</i>
<u>9</u>	<u>18%</u> more than 5 times monthly
<u>12</u>	<u>24%</u> 2 - 5 times monthly
<u>5</u>	<u>10%</u> 1 time monthly
<u>24</u>	<u>48%</u> Rarely or Never

6. Were there instances in which a wrong address from a PBX call caused you a problem?

<i>Number of PSAPs Responding</i>	<i>Percent of Respondents</i>
<u>27</u>	<u>56.3%</u> Yes
<u>21</u>	<u>43.8%</u> No

7. If yes, how often did a wrong address from a PBX call cause a problem?.

<i>Number of PSAPs Responding</i>	<i>Percent of Respondents</i>
<u>2</u>	<u>6%</u> more than 5 times monthly
<u>7</u>	<u>20%</u> 2 - 5 times monthly
<u>3</u>	<u>8%</u> 1 time monthly
<u>23</u>	<u>66%</u> Rarely or Never

8. Did the wrong address from a PBX call lead to a dispatch to a wrong address?

*Number of PSAPs Responding*

14  
33

*Percent of Respondents*

29.8% Yes  
70.2% No

9. If yes, how often did the wrong address from a PBX call lead to a dispatch to a wrong address?

*Number of PSAPs Responding*

0  
2  
3  
22

*Percent of Respondents*

0% more than 5 times monthly  
8% 2 - 5 times monthly  
11% 1 time monthly  
81% Rarely or Never

10. Did the wrong address from a PBX call cause a delay in dispatching?

*Number of PSAPs Responding*

19  
27

*Percent of Respondents*

41.3% Yes  
58.7% No

11. If yes, how often did the wrong address from a PBX call cause a delay in dispatching?

*Number of PSAPs Responding*

2  
5  
3  
17

*Percent of Respondents*

7% more than 5 times monthly  
19% 2 - 5 times monthly  
11% 1 time monthly  
63% Rarely or Never

12. Other comments? \_\_\_\_\_  
\_\_\_\_\_  
\_\_\_\_\_

Name of official completing survey:

Title:

Date:

Address & Email:

Please return to:  
Legislative Research Commission  
State Capitol  
700 Capital Avenue  
Frankfort, KY 40601-3486  
Attn: Matt Udie

**APPENDIX C**

**STATUTES FROM OTHER STATES REGARDING PRIVATE MULTI-LINE  
TELEPHONE SYSTEMS**



## CONNECTICUT

### Title 28, Chapter 518a: EMERGENCY TELECOMMUNICATIONS

Section 28-25a: Telephone companies shall provide selective routing, automatic number identification and location identification as a tariffed service by Dec. 31, 1989.

#### Section 28-25b: Public Safety Answering Points

(e) Provides that before installing E911 service to a municipality, the municipality must submit a PBX 9-1-1 utilization plan to the Office of State-wide Emergency Telecommunications.

## ILLINOIS

### Chapter 50: Local Government, Police, Fire, and Emergency Services

#### 750: Emergency Telephone System Act

**50 ILCS 750/2.16:** Defines private business switch service to include Centrex type service and PBX systems. Defines types of Key systems included and those excluded from statute.

**50 ILCS 750/2.17:** Defines private residential switch service. Lists typical users of private residential switch services.

#### **50 ILCS 750/15.5: Residential Requirements**

(Statute became effective on Sept. 1, 1994)

(a) Requires those providing or operating a private residential switch service to provide end users the same level of 9-1-1 service as public agencies and telecommunications carriers are providing other residential end users of local 9-1-1 systems. Must include the capability to identify the telephone number, extension number and physical location of the *source* of the call, not switch location. Applicable after June 30, 1995.

(b) The private residential switch operator is responsible for forwarding end user automatic location identification record information to 9-1-1 system provider.

(c) Act does not apply to PBX telephone extensions using radio transmissions to convey electrical signals directly between the telephone extension and serving PBX.

#### **50 ILCS 750/15.6: Business Requirements**

(a) Requires same level of service as above. Must include the capability to identify the telephone number, extension number and physical location of the *source* of the call, not switch location. All entities operating a private business switch service must be in compliance by June 30, 1999.

(b) Private business switch service must forward information, as above.

(c) Not applicable to radio transmission systems.

## **MISSISSIPPI**

Mississippi Code Annotated, Title 19, Chapter 5: HEALTH, SAFETY AND PUBLIC WELFARE, EMERGENCY TELEPHONE SERVICE.

SEC. 19-5-309 refers to Shared Tenant Services (STS) and PBXs.

(a) Counties greater than 15,000 not currently in the process of installing 9-1-1 service, or currently using 9-1-1 emergency telephone service, when authorized by a majority vote of the Board of Commissioners shall take steps necessary to implement E911.

(b) Counties less than 15,000 not currently in the process of installing 9-1-1, or currently using 9-1-1 emergency telephone service, when authorized by a majority vote of the Board of Commissioners shall install either "Basic 9-1-1" or "Enhanced 9-1-1."

Deadlines:

(1) After Dec. 31, 1993: All operators of Shared Tenant Service (STS) type of telephone service shall be E911 compatible;

(2) Five (5) years after effective date of statute: All service suppliers within Mississippi shall comply with NENA data and operational standards.

## **TEXAS**

### **Texas Health and Safety Code Chapter 722**

(HB 1544: PRIVATE SWITCH 9-1-1 LEGISLATION OF 1993)

Subchapter B: Counties of over 2 million population

Sec. 772.118: Number and Location Identification

(a) Service supplier shall furnish the telephone number and location associated with the number.

(b) A business service user that provides residential facilities and owns or leases a publicly or privately owned switches shall provide to those residential end users the same level of 9-1-1 service that a service suppliers is required to provide to other residential end users in the district.

Subchapter C: Counties with population over 860,000

Section 772.218: Same as above

Subchapter D: Counties with population over 20,000

Section 772.318: Same as above

Subchapter E: Counties with population over 1.5 million



Section 772.406: Same as (b) above

All Business Service Users and/or Private Switch Providers utilizing private switches in residential facilities, are required to implement and maintain E911 service. In addition, they are required to collect the 9-1-1 service fee from residents of these residential facilities, and to transmit the fees monthly, to the agency administering 9-1-1 service in the jurisdiction in which the facility is located.

"Business service user" means a business that provides telecommunications service, including 9-1-1 service, to residential end users through a private telephone switch.

#### COUNCILS OF GOVERNMENTS

Under this legislation, 9-1-1 service is administered on the local level by twenty-four Councils of Governments throughout the state.

#### ADVISORY COMMISSION ON STATE EMERGENCY COMMUNICATIONS

This body has rule making authority relating to 9-1-1 service fees, the level of service, and the budgets for 9-1-1 service proposed by the Councils of Governments.

#### WASHINGTON

##### **RCW 80.36.555:** E911 service - Residential service required

Requires that by January 1, 1997 (or such time that a private switch automatic location identification service approved by the WA utilities and transportation commission is available, whichever is later) all residential customers serviced by a PBX system must transmit the location of the individual residential unit that places the 911 call.

##### **RCW 80.36.560:** Business Service required

Requires that by January 1, 1997, shared tenant business PBX systems shall provide location identification for extensions. Requirement limited to businesses containing a physical area exceeding 25,000 sq feet, businesses located on more than one floor, office buildings serving more than one business, or businesses having multiple locations.

##### **RCW 28A.335.320:** Mandates that common and public schools provide location information for all extensions.